



## Finishing Systems



w e l c o m e

Press  to continue

[Workbook](#) 

Welcome to the Konica Minolta OUTWARD Finishing Systems course.  
Click the forward arrow to begin the course.

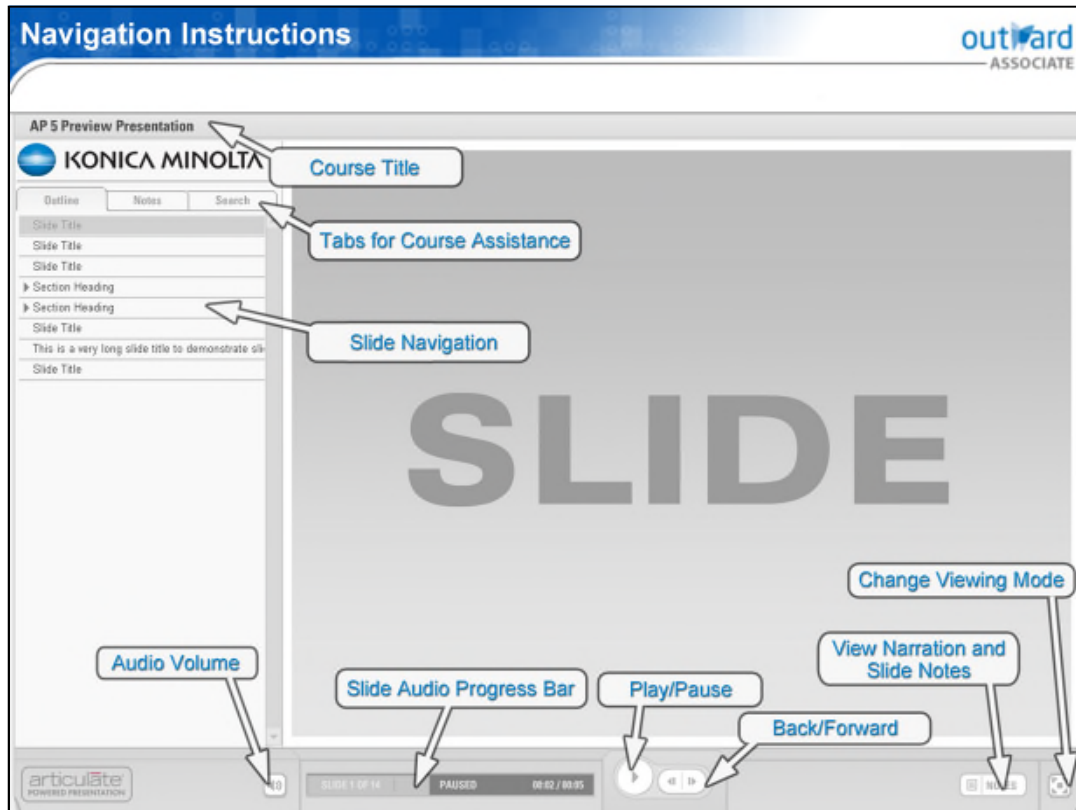

Here are the instructions on how to navigate through this course.



### Course Objectives

- Identify different types of finishing systems and the components within the systems.
- Explain the theory of operation of these systems
- Explain the maintenance procedures associated with these systems
- Identify finisher adjustment concepts
- Reference the various types of service support documentation available to the technician.
- Comply with any safety concerns.

**Please Note:** The estimated time to completion this course is 70 - 80 minutes

The objectives for this course are:

- Identify different types of finishing systems and the components within the systems.
- Explain the theory of operation of these systems
- Explain the maintenance procedures associated with these systems
- Identify finisher adjustment concepts
- Reference the various types of service support documentation available to the technician.
- Comply with any safety concerns.

- Определите различные типы отделочных систем и компонентов внутри систем.
- Объясните теорию работы этих систем
- Объясните процедуры обслуживания, связанные с этими системами
- Определить концепции регулировки финишера
- Ссылка на различные виды документации сервисной поддержки, доступные для технического специалиста.
- Соблюдайте все требования безопасности.

Finishing Systems are designed to provide supplemental output capability for copiers and printers. They are capable of sorting copies and stapling them together to create sets of copies.

Here's an example of a Production Print MFP with Finishing systems attached:

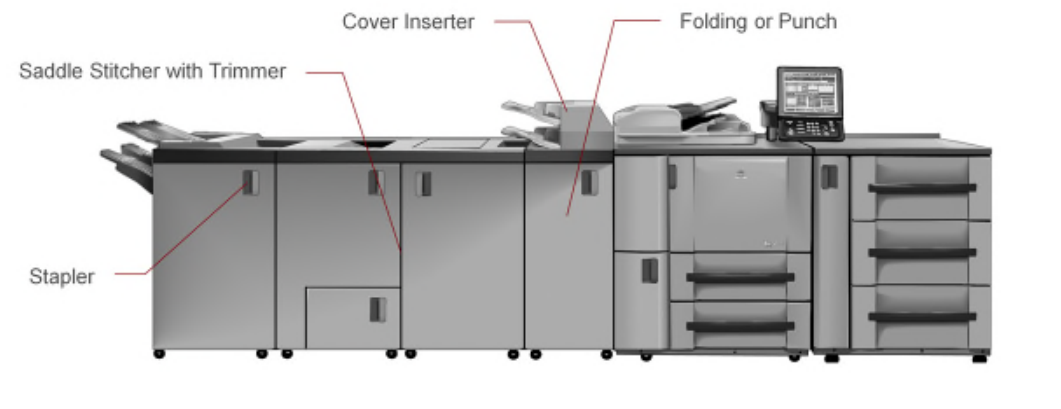

Finishing Systems are designed to provide supplemental output capability for copiers and printers. They are capable of sorting copies and stapling them together to create sets of copies. Here's an example of a Production Print MFP with Finishing systems attached:

Отделочные системы предназначены для обеспечения дополнительных возможностей вывода для копиров и принтеров. Они способны сортировать копии и скреплять их вместе для создания наборов копий. Вот пример МФП Production Print с подключенными системами отделки:

Finishing systems can generally be divided into either Sorters, or Finishers. They are able to sort, group, staple, or fold the copied paper. Some have the ability to accept various finishing accessories such as Hole punching, trimming, or cover insertion.

Finishers are usually the most capable of all output devices and can perform most if not all of the previously mentioned abilities.

Sorters can be as basic as a sort only device without the ability to be upgraded or enhanced with additional options.

We will be discussing Finishers at length in this program with references to sorters where necessary.



Finishing systems can generally be divided into either Sorters, or Finishers. They are able to sort, group, staple, or fold the copied paper. Some have the ability to accept various finishing accessories such as Hole punching, trimming, or cover insertion.

Finishers are usually the most capable of all output devices and can perform most if not all of the previously mentioned abilities.

Sorters can be as basic as a sort only device without the ability to be upgraded or enhanced with additional options.

We will be discussing Finishers at length in this program with references to sorters where necessary.

Финишные системы обычно можно разделить на сортировщиков или финишеров. Они могут сортировать, группировать, скреплять или складывать скопированную бумагу. У некоторых есть возможность принимать различные отделочные аксессуары, такие как перфорация, обрезка или вставка крышки.

Финишеры, как правило, наиболее эффективны из всех устройств вывода и могут выполнять большинство, если не все из ранее упомянутых способностей.

Сортировщики могут быть такими же простыми, как устройство, предназначенное только для сортировки, без возможности обновления или улучшения с помощью дополнительных опций.

Мы будем подробно обсуждать финишеров в этой программе со ссылками на сортировщики, где это необходимо.

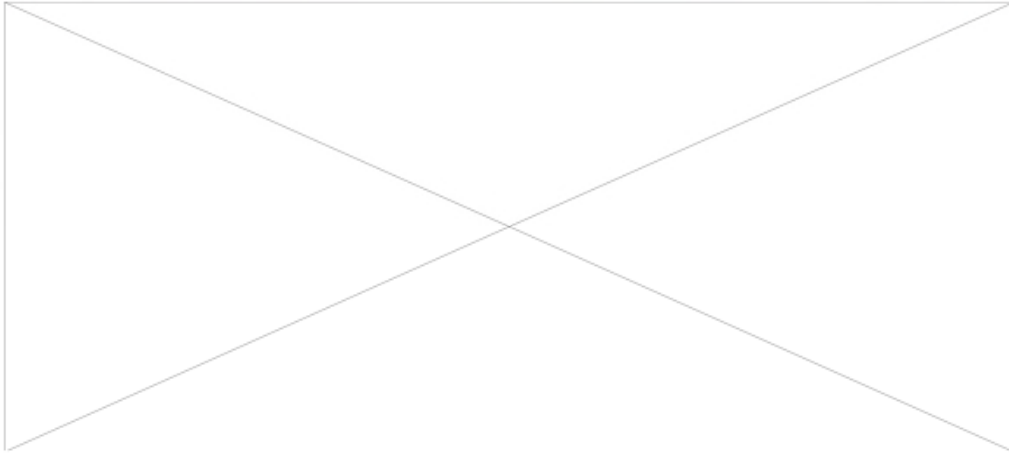

Here is an interaction which covers the main finishing components. Click on each button to see some information.



## Lessons

The following lessons are covered in this course:

- Lesson 1: Drive
- Lesson 2: Paper Transport
- Lesson 3: Main and Sub Trays
- Lesson 4: Stacker Section
- Lesson 5: Stapler Section
- Lesson 6: Folding Section
- Lesson 7: Post Inserter
- Lesson 8: Hole Punch Section
- Lesson 9: Trimmer
- Lesson 10: Perfect Binder

The following lessons are covered in this course.

## Drive

The topics of discussion are:

- General Statement
- Theory of Operation
- Preventative Maintenance and Safety
- Removal Procedure
- Disassembly/Reassembly
- Adjustments
- Malfunction Codes

The following topics within the Drive lesson will be covered.

## 1.1 General Statement

Finishers, or Sorters provide mechanical drive to their components from various sources, some internally as well as externally. Usually mechanical drive for the finishing systems is located at the back or rear of the unit.



Finishers, or Sorters provide mechanical drive to their components from various sources, some internally as well as externally. Usually mechanical drive for the finishing systems is located at the back or rear of the unit.

Финишеры, или сортировщики, обеспечивают механический привод своих компонентов из различных источников, как внутренних, так и внешних. Обычно механический привод для отделочных систем расположен сзади или сзади агрегата.

## 1.2 Theory of Operation

In most Finishers, and some fast Sorters, the mechanical drive sources are internally mounted DC Motors that receive power from internal power supplies or from a wired interface with the copier or printer power supplies.

Some slower sorters may receive drive from gears linked to the exit or fusing unit of the copier to which they are attached.

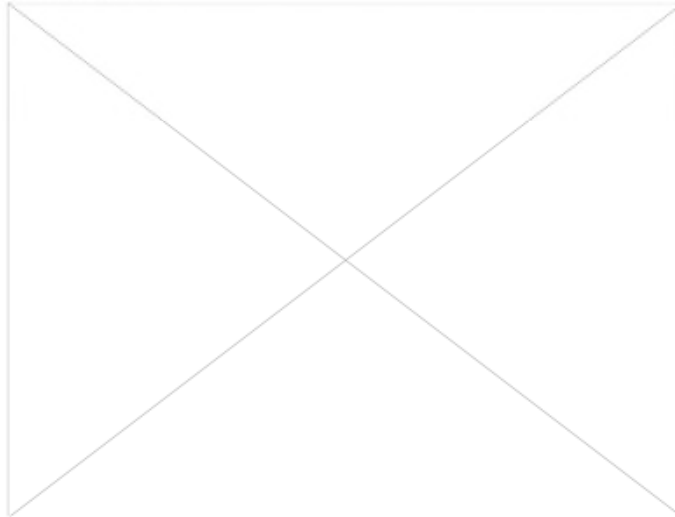

In most Finishers, and some fast Sorters, the mechanical drive sources are internally mounted DC Motors that receive power from internal power supplies or from a wired interface with the copier or printer power supplies.

Some slower sorters may receive drive from gears linked to the exit or fusing unit of the copier to which they are attached.

В большинстве финишеров и некоторых быстрых сортировщиках источники с механическим приводом представляют собой встроенные двигатели постоянного тока, которые получают питание от внутренних источников питания или от проводного интерфейса с источниками питания копира или принтера.

Некоторые более медленные сортировщики могут получать привод от зубчатых колес, связанных с блоком выхода или термозакрепления копира, к которому они прикреплены.

### 1.3 Preventative Maintenance and Safety

outward  
ASSOCIATE

You should Inspect the condition and the tension of the drive belts, or the gear mesh during a Service call or a Preventative Maintenance Procedure.

If you must test run the finisher with the exterior covers removed, be careful to avoid the gears and belts as your hands or clothing may become entangled.

You should Inspect the condition and the tension of the drive belts, or the gear mesh during a Service call or a Preventative Maintenance Procedure.

If you must test run the finisher with the exterior covers removed, be careful to avoid the gears and belts as your hands or clothing may become entangled.

Вы должны проверить состояние и натяжение приводных ремней или зубчатой передачи во время сервисного вызова или процедуры профилактического обслуживания.

Если вам необходимо выполнить пробный запуск финишера со снятыми внешними крышками, будьте осторожны, чтобы не зацепить шестерни и ремни, так как ваши руки или одежда могут запутаться.

## 1.4 Removal Procedure

Reference the Service Manual for specific procedures on how to remove the unit.

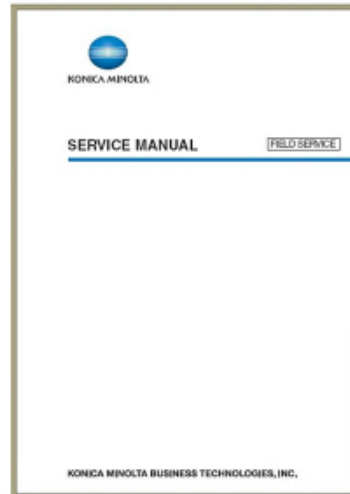

Reference the Service Manual for specific procedures on how to remove the unit.

## 1.5 Disassembly/Reassembly

outward  
ASSOCIATE

Be careful when removing the belts, gears, or motors so as not to lose any steel drive pins that may be recessed into the back of a drive gear. Also, avoid damaging any retaining clips that hold the gears to the drive shafts, they may become deformed.

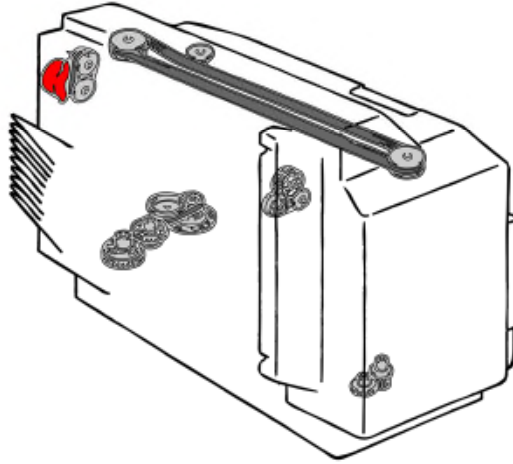

Be careful when removing the belts, gears, or motors so as not to lose any steel drive pins that may be recessed into the back of a drive gear. Also, avoid damaging any retaining clips that hold the gears to the drive shafts, they may become deformed.

Будьте осторожны при снятии ремней, зубчатых колес или двигателей, чтобы не потерять стальные ведущие штифты, которые могут быть утоплены в заднюю часть ведущей шестерни. Кроме того, избегайте повреждения любых фиксирующих зажимов, которые крепят шестерни к приводным валам, они могут деформироваться.

## 1.6 Adjustments

The belt tension must be checked periodically for the proper deflection in millimeters, or pressure by using a metric spring gauge that measures grams of force.

Reference the Adjustment section of the appropriate service manual for details.

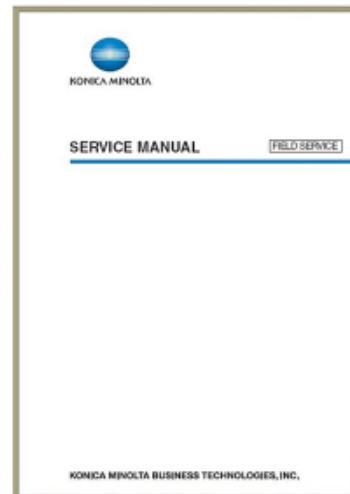

The belt tension must be checked periodically for the proper deflection in millimeters, or pressure by using a metric spring gauge that measures grams of force.

Reference the Adjustment section of the appropriate service manual for details.

Натяжение ремня должно периодически проверяться на предмет правильного прогиба в миллиметрах или давления с помощью метрического пружинного манометра, который измеряет грамм силы.

За подробностями обращайтесь к разделу «Регулировка» соответствующего руководства по обслуживанию.

## 1.7 Malfunction Codes

There are many codes related to the drive mechanisms. You should consult the troubleshooting manual to guide you to the possible problem.

There are many codes related to the drive mechanisms. You should consult the troubleshooting manual to guide you to the possible problem.

## 1.8 Quiz

Question 1 of 2

Finishers receive mechanical drive from internal DC motors, not external drive gears.

- True
- False

### PROPERTIES

On passing, 'Finish' button:

On failing, 'Finish' button:

Allow user to leave quiz:

User may view slides after quiz:

User may attempt quiz:

[Goes to Next Slide](#)

[Goes to Next Slide](#)

[At any time](#)

[At any time](#)

[Unlimited times](#)

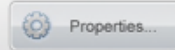

## 1.9 Review

You should now have knowledge of the drive provided and from where it receives power. The next topic we will discuss is the Paper Transport, or Conveyance Path and how it may differ from one finisher to another.

You should now have knowledge of the drive provided and from where it receives power. The next topic we will discuss is the Paper Transport, or Conveyance Path and how it may differ from one finisher to another.

## Paper Transport

The topics of discussion are:

- General Statement
- Location
- Theory of Operation
- Preventative Maintenance
- Removal Procedure
- Disassembly/Reassembly
- Maintenance Codes and Counters
- Adjustments
- Theoretical Troubleshooting

The following topics within the Paper Transport lesson will be covered.

## 2.1 General Statement

Finishers and some high-end Sorters have elaborate paper paths to convey or transport the copy paper to various finishing processes within the unit.

Finishers and some high-end Sorters have elaborate paper paths to convey or transport the copy paper to various finishing processes within the unit.

Финишеры и некоторые высококлассные сортировщики разработали пути прохождения бумаги для транспортировки или транспортировки копировальной бумаги для различных процессов отделки внутри устройства.

## 2.2 Location

The paper path on some finishers may be quite extensive.

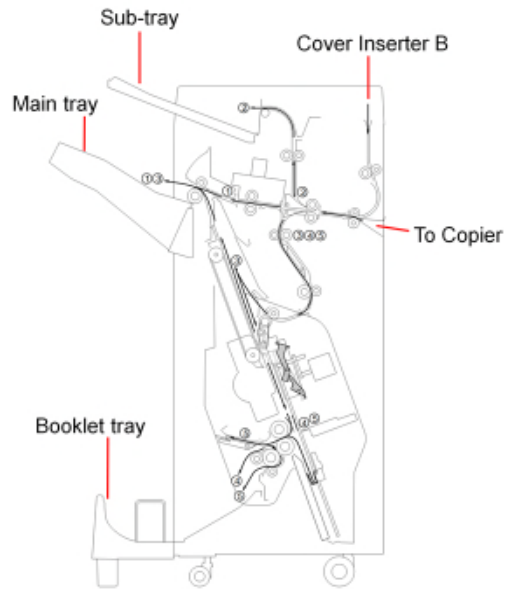

The paper path on some finishers may be quite extensive.

## 2.3 Theory of Operation (1/2)

Finishers and Sorters usually have at least three Modes; Non-Sort, Sort, and Group that manipulate the copies coming from the copier or printer. The orientation of the paper, either face up or down is determined in most cases from copy job selections made by the user.

The Non-Sort Mode carries the output copy from the copier directly to a Main Tray that receives the paper.

The Sort, and Group Modes carry the copies from the copier to a Main Tray however each set of copies is shifted by a shift unit, or a similar device, that keeps the sets separated. These sets are not stapled at this time.

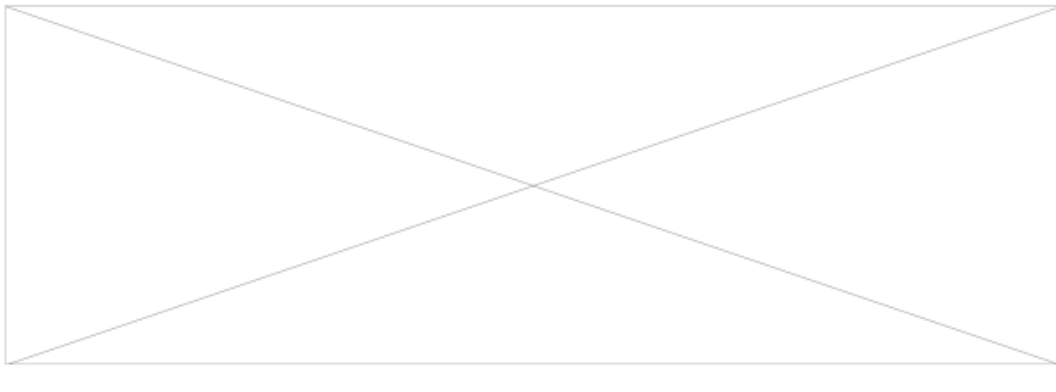

Finishers and Sorters usually have at least three Modes; Non-Sort, Sort, and Group that manipulate the copies coming from the copier or printer. The orientation of the paper, either face up or down is determined in most cases from copy job selections made by the user.

The Non-Sort Mode carries the output copy from the copier directly to a Main Tray that receives the paper.

The Sort, and Group Modes carry the copies from the copier to a Main Tray however each set of copies is shifted by a shift unit, or a similar device, that keeps the sets separated. These sets are not stapled at this time.

У финишеров и сортировщиков обычно есть как минимум три режима; Non-Sort, Sort и Group, которые манипулируют копиями, поступающими с копира или принтера. Ориентация бумаги, лицевой стороной вверх или вниз, определяется в большинстве случаев на основе выбранных пользователем заданий на копирование.

Режим «Без сортировки» переносит выходную копию с копира непосредственно в основной лоток, в который поступает бумага.

Режимы сортировки и группирования переносят копии с копира в основной лоток, однако каждый набор копий смещается на единицу сдвига или аналогичное устройство, которое поддерживает разделение наборов. Эти наборы не сшиты в это время.

Some slower sorters use either 10, or 20 individual bins to sort or group the copies. The Bins move up or down to perform the sorting operation.

The Sub-Tray Mode carries the copy in this example to the Sub-Tray either face up or down.

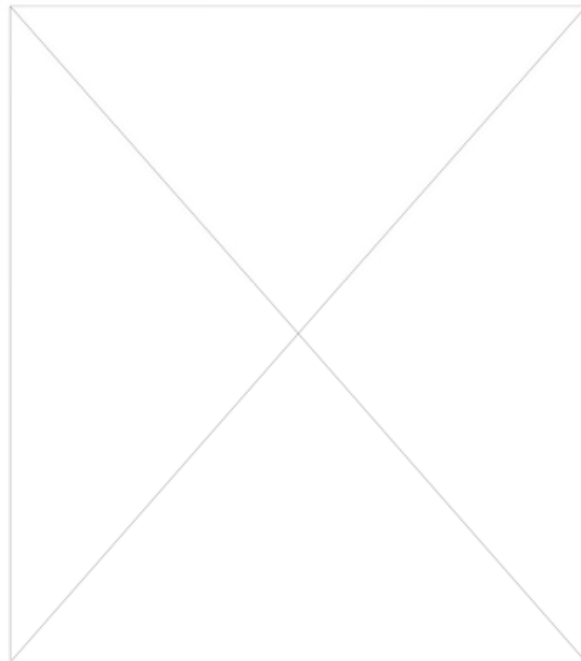

Some slower sorters use either 10, or 20 individual bins to sort or group the copies. The Bins move up or down to perform the sorting operation.

The Sub-Tray Mode carries the copy in this example to the Sub-Tray either face up or down.

Некоторые более медленные сортировщики используют 10 или 20 отдельных корзин для сортировки или группировки копий. Контейнеры перемещаются вверх или вниз для выполнения сортировки.

В этом режиме копия этого лотка переносится в дополнительный лоток лицевой стороной вверх или вниз.

## 2.4 Preventative Maintenance and Safety

During a Preventative Maintenance Procedure, the rollers that transport the paper may be covered with paper dust or lint, and should be cleaned following the procedures in the service manual.

Always turn off the copier or printer and unplug the connection from the copier to the finisher, or sorter before working in the unit.

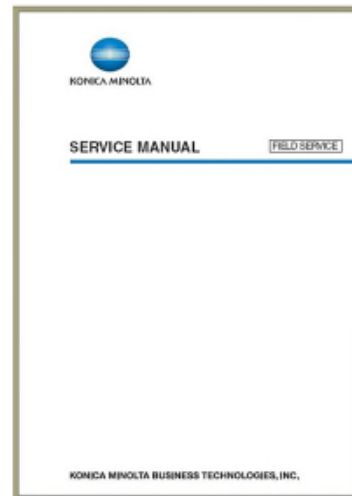

During a Preventative Maintenance Procedure, the rollers that transport the paper may be covered with paper dust or lint, and should be cleaned following the procedures in the service manual.

Always turn off the copier or printer and unplug the connection from the copier to the finisher, or sorter before working in the unit.

## 2.5 Removal Procedure

Roller removal procedures vary according to the model you are servicing. You should reference the applicable service manual for the correct procedures.

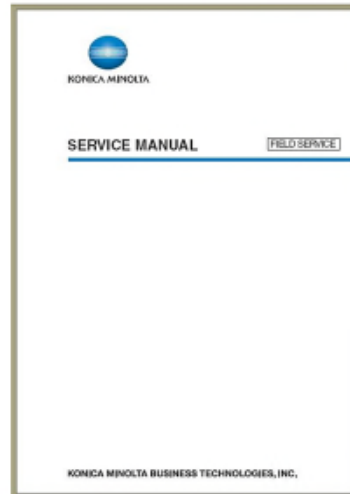

Roller removal procedures vary according to the model you are servicing. You should reference the applicable service manual for the correct procedures.

## 2.6 Adjustments

The belt or gears that drive the rollers may need to be adjusted over time or when a paper jam continually repeats. Never over tighten this adjustment, as it could damage related components.

The belt or gears that drive the rollers may need to be adjusted over time or when a paper jam continually repeats. Never over tighten this adjustment, as it could damage related components.

## 2.7 Malfunction Codes

The motors may generate a code if there is a paper jam that stops the rollers and prevents the motor from turning.

Jam codes may occur if there is a paper handling problem in the paper path such as a timing issue were a piece of paper is unable to activate a sensor at the appropriate time.

The motors may generate a code if there is a paper jam that stops the rollers and prevents the motor from turning.

Jam codes may occur if there is a paper handling problem in the paper path such as a timing issue were a piece of paper is unable to activate a sensor at the appropriate time.

Двигатели могут генерировать код, если есть застревание бумаги, которое останавливает ролики и препятствует вращению двигателя.

Коды замятия могут возникать, если в тракте бумаги возникла проблема с обращением с бумагой, например, проблема с синхронизацией, когда лист бумаги не может активировать датчик в соответствующее время.

## 2.8 Quiz

Question 1 of 2

The belts or gears that drive the rollers may need to be adjusted over time.

- True
- False

### PROPERTIES

On passing, 'Finish' button:

On failing, 'Finish' button:

Allow user to leave quiz:

User may view slides after quiz:

User may attempt quiz:

[Goes to Next Slide](#)

[Goes to Next Slide](#)

[At any time](#)

[At any time](#)

[Unlimited times](#)

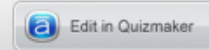
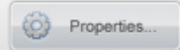

## 2.9 Review

You should now have knowledge of the Paper Transport, or Conveyance Path and the various paths the paper takes to exit the finisher or sorter.

The next topics we will discuss are the Main Tray and Sub-Tray and how they function.

You should now have knowledge of the Paper Transport, or Conveyance Path and the various paths the paper takes to exit the finisher or sorter.

The next topics we will discuss are the Main Tray and Sub-Tray and how they function.

Теперь вы должны знать о пути транспортировки бумаги или пути транспортировки и различных путях, по которым бумага выходит из финишера или сортировщика.  
Следующие темы, которые мы обсудим, - это основной лоток и вспомогательный лоток, а также их функционирование.

### Main and Sub Trays

The topics of discussion are:

- General Statement
- Theory of Operation
- Safety Concerns
- Removal Procedures
- Adjustments and Codes

The following topics within the Main and Sub Tray lesson will be covered.

### 3.1 General Statement

The Main and Sub Trays are responsible for receiving the copy paper or sets of copies as they exit from the finisher, or sorter.

Both trays are located at the exit end of the finisher and are usually positioned one above the other with the Sub Tray on top.

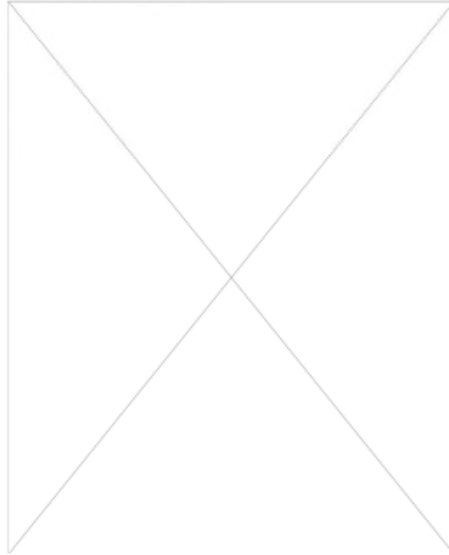

The Main and Sub Trays are responsible for receiving the copy paper or sets of copies as they exit from the finisher, or sorter.

Основной и вспомогательный лотки отвечают за прием копировальной бумаги или комплектов копий при выходе из финишера или сортировщика.

Оба лотка расположены на выходном конце финишера и обычно располагаются один над другим с дополнительным лотком наверху.

### 3.2 Theory of Operation (1/2)

The Sub Tray is typically fixed, and is adjustable to receive up to 12 x 18 inch paper, lengthwise.

The Main Tray is more complex; as it usually moves up or down to adjust its' position to receive subsequent sheets, or sets of copies up to 12 x 18 inch paper. The mechanism consists of a lift motor, cables, or chains, drive pulleys or sprockets, and limit sensors.



The Sub Tray is typically fixed, and is adjustable to receive up to 12 by 18 inch paper, lengthwise.

The Main Tray is more complex; as it usually moves up or down to adjust its' position to receive subsequent sheets, or sets of copies up to 12 by 18 inch paper. The mechanism consists of a lift motor, cables, or chains, drive pulleys or sprockets, and limit sensors.

Дополнительный лоток обычно фиксируется и может регулироваться для приема бумаги размером до 12 на 18 дюймов в длину.

Основной лоток более сложный; обычно он перемещается вверх или вниз, чтобы отрегулировать свое положение для получения последующих листов, или наборов копий размером до 12 на 18 дюймов. Механизм состоит из подъемного двигателя, тросов или цепей, приводных шкивов или звездочек и датчиков предела.

The sensors ensure that the tray does not overdrive in either direction, which could damage the cables or drive pulleys. In addition, the sensors serve as a reference for the system to know where the tray is.

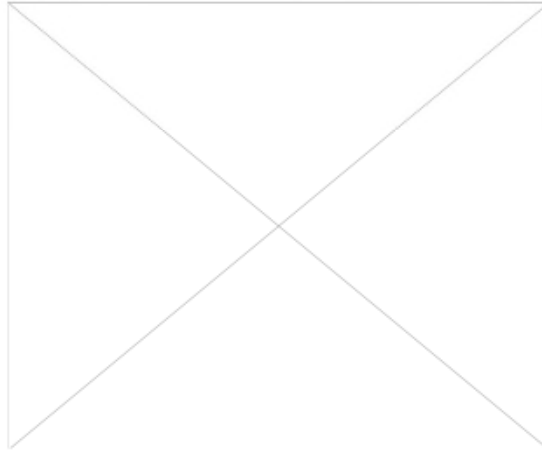

The sensors ensure that the tray does not overdrive in either direction, which could damage the cables or drive pulleys. In addition, the sensors serve as a reference for the system to know where the tray is.

Датчики гарантируют, что лоток не будет перегружен в любом направлении, что может повредить кабели или приводные шкивы. Кроме того, датчики служат системой для определения того, где находится лоток.

### 3.3 Safety Concerns

Do not release the wire lift cables in this example with the Main Tray in the raised position as it could fall and become damaged or injure someone.

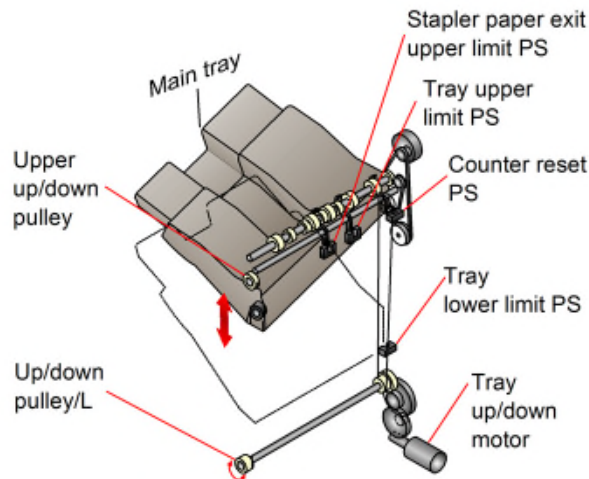

Do not release the wire lift cables in this example with the Main Tray in the raised position as it could fall and become damaged or injure someone.

В этом примере не отпускайте кабельные подъемники, когда основной лоток находится в поднятом положении, так как он может упасть и получить повреждения или травму.

### 3.4 Removal Procedure

Use the proper removal procedures in the service manual to avoid dropping the Main Tray.

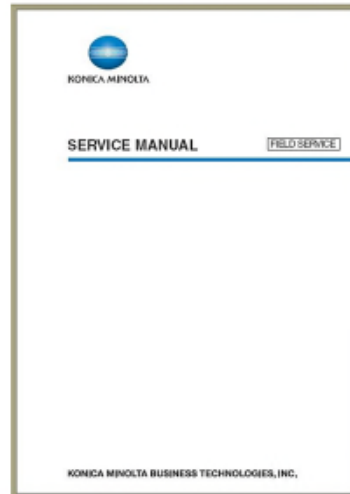

Use the proper removal procedures in the service manual to avoid dropping the Main Tray.

### 3.5 Adjustments and Codes

The tension of the wire cables and chains if used must be adjusted according to the specifications in the service manual. Never over tighten this adjustment as it could damage related components such as drive pulleys.

The lift motor may generate codes if the Main Tray goes beyond the limit sensors and bottoms out.

The tension of the wire cables and chains if used must be adjusted according to the specifications in the service manual. Never over tighten this adjustment as it could damage related components such as drive pulleys.

The lift motor may generate codes if the Main Tray goes beyond the limit sensors and bottoms out.

Натяжение проводных кабелей и цепей, если они используются, должно быть отрегулировано в соответствии со спецификациями в руководстве по обслуживанию. Никогда не затягивайте эту настройку слишком сильно, поскольку это может повредить связанные компоненты, такие как приводные шкивы.

Подъемный двигатель может генерировать коды, если основной лоток выходит за пределы датчиков пределов и выдвигается снизу.

### 3.6 Quiz

Question 1 of 2

The tension of the wire cables and chains if used must be adjusted according to the specifications in the service manual.

- True
- False

#### PROPERTIES

On passing, 'Finish' button:

On failing, 'Finish' button:

Allow user to leave quiz:

User may view slides after quiz:

User may attempt quiz:

[Goes to Next Slide](#)

[Goes to Next Slide](#)

[At any time](#)

[At any time](#)

[Unlimited times](#)

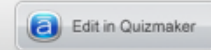
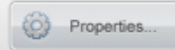

### 3.7 Review

You should now have knowledge of the Main Tray, and Sub-Tray and how they function.  
The next topic we will discuss is the Stacker Section where we will see how it functions.

You should now have knowledge of the Main Tray, and Sub-Tray and how they function.  
The next topic we will discuss is the Stacker Section where we will see how it functions.

## Stacker Section

The topics of discussion are:

- General Statement
- Theory of Operation
- Preventative Maintenance & Safety
- Adjustments
- Malfunction Codes
- Theoretical Troubleshooting

The following topics within the Stacker Section lesson will be covered.

## 4.1 General Statement

A Stacker is available in some finishers and is used to stack incoming copies which can be processed further depending on user finishing selections.

The location of the Stacker is usually in the lower half of the finisher.

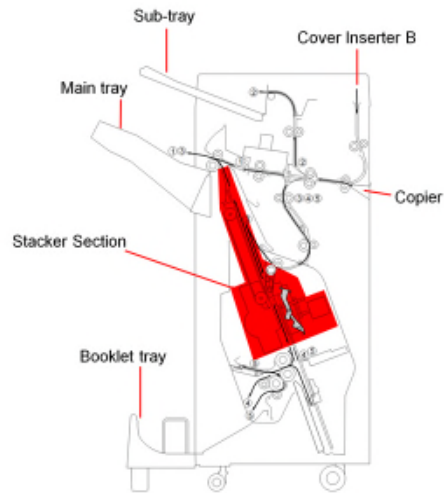

A Stacker is available in some finishers and is used to stack incoming copies which can be processed further depending on user finishing selections.

The location of the Stacker is usually in the lower half of the finisher.

Укладчик доступен в некоторых финишерах и используется для укладки входящих копий, которые могут быть обработаны в дальнейшем в зависимости от выбора пользователя при финишной обработке.

Расположение укладчика обычно находится в нижней половине финишера.

## 4.2 Theory of Operation

A Stacker is comprised of many components working together to deliver the copy paper to an area and align it into a neat stack.

The paper is pulled into the stacker by a roller that releases the paper and allows it to fall against a Flat-Stapling Stopper for stapling alignment, or a Booklet Stopper for folding.

Alignment plates move toward one another to push each sheet into a neat stack, readying the stack for further finisher processes such as stapling or folding.

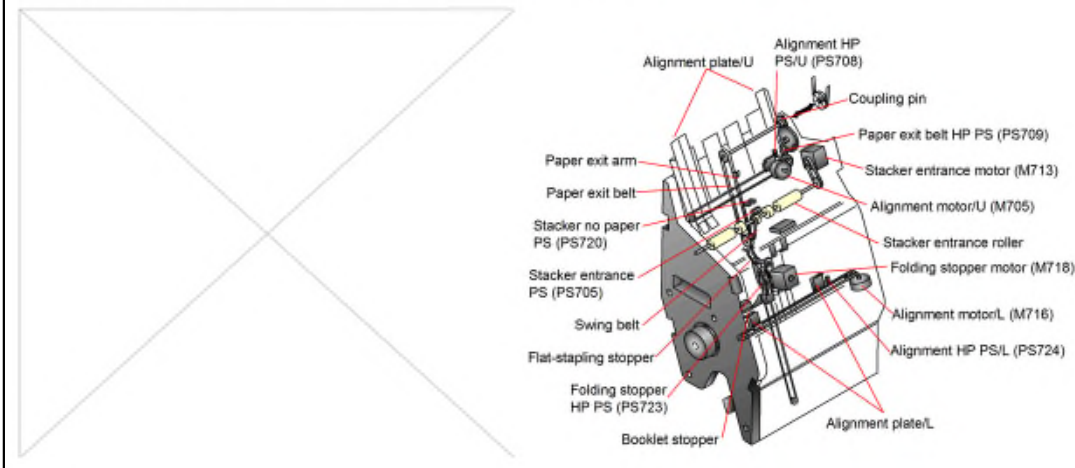

A Stacker is comprised of many components working together to deliver the copy paper to an area and align it into a neat stack.

The paper is pulled into the stacker by a roller that releases the paper and allows it to fall against a Flat-Stapling Stopper for stapling alignment, or a Booklet Stopper for folding.

Alignment plates move toward one another to push each sheet into a neat stack, readying the stack for further finisher processes such as stapling or folding.

Укладчик состоит из множества компонентов, работающих вместе, чтобы доставить бумагу для копий в область и выровнять ее в аккуратную стопку.

Бумага втягивается в укладчик с помощью ролика, который высвобождает бумагу и позволяет ей упасть на стопор для плоского сшивания для выравнивания сшивания или стопор для брошюр для складывания.

Выравнивающие пластины движутся навстречу друг другу, чтобы протолкнуть каждый лист в аккуратную стопку, подготавливая стопку к дальнейшим процессам финишной обработки, таким как сшивание или сгибание.

### 4.3 Preventative Maintenance & Safety

During a Preventative Maintenance Procedure, the Stacker mechanisms should be inspected for proper operation.

Use routine precautions when working with moving parts.

During a Preventative Maintenance Procedure, the Stacker mechanisms should be inspected for proper operation.

Use routine precautions when working with moving parts.

Во время процедуры профилактического технического обслуживания механизмы укладчика должны быть проверены на предмет правильной работы.

При работе с движущимися частями соблюдайте обычные меры предосторожности.

## 4.4 Adjustments

If adjustments are necessary, reference the appropriate service manuals.

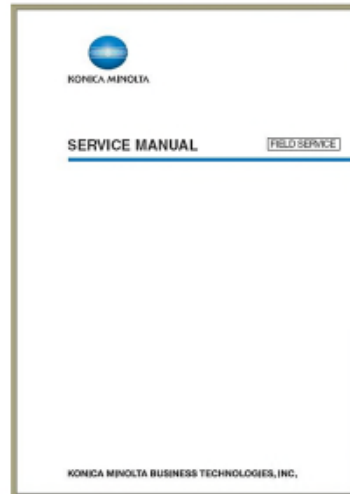

If adjustments are necessary, reference the appropriate service manuals.

## 4.5 Malfunction Codes

The Stacker will generate codes if components were to bind or malfunction.

The Stacker will generate codes if components were to bind or malfunction.

Укладчик будет генерировать коды, если компоненты должны были связываться или работать неправильно.

## 4.6 Quiz

Question 1 of 2

A Stacker is comprised of many components working together to deliver the copy paper to an area to be aligned into a neat stack.

- True
- False

### PROPERTIES

On passing, 'Finish' button:

On failing, 'Finish' button:

Allow user to leave quiz:

User may view slides after quiz:

User may attempt quiz:

[Goes to Next Slide](#)

[Goes to Next Slide](#)

[At any time](#)

[At any time](#)

[Unlimited times](#)

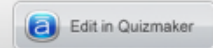
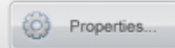

## 4.7 Review

You should now be familiar with the Stacker and how it functions.

The next topic we will discuss is the Stapler, its' different configurations and output.

You should now be familiar with the Stacker and how it functions.

The next topic we will discuss is the Stapler, its' different configurations and output.

## Stapler Section

The topics of discussion are:

- General Statement
- Location
- Theory of Operation
- Preventative Maintenance & Safety
- Removal Procedures
- Disassembly/Reassembly
- Adjustments & Malfunction Codes

The following topics within the Stapler Section lesson will be covered.

## 5.1 General Statement

Many Finishers and Sorters contain Stapling mechanisms consisting of either one or two Stapler Units. Staples may be inserted into the corner of a stack of paper, or into the fold of what would then be a bound booklet.

- 11 x 17 is equivalent to A3
- 8½ x 11 is equivalent to A4

### Corner Staple

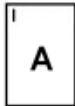

Paper Size:  
(11x17) (Legal)  
(Letter) (LetterS)

### 2-Point Staple

#### Side Staple



Paper Size:  
(11x17) (Legal)  
(Letter) (LetterS)

#### Center Staple



Paper Size:  
(11x17) (Letter)



Many Finishers and Sorters contain Stapling mechanisms consisting of either one or two Stapler Units. Staples may be inserted into the corner of a stack of paper, or into the fold of what would then be a bound booklet.

Многие финишеры и сортировщики содержат сшивающие механизмы, состоящие из одного или двух сшивателей. Скрепки могут быть вставлены в угол стопки бумаги или в сгиб того, что тогда будет переплетенным буклетом.

## 5.2 Location

Stapling Mechanisms may be located in many locations throughout the various Finishers and Sorters available. In this example, it is located near the Stacker Unit.

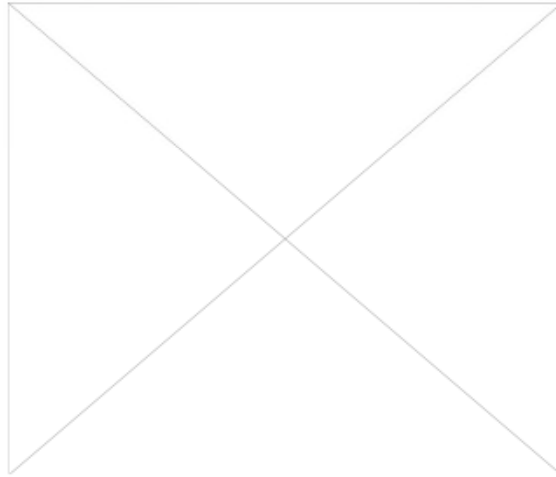

Stapling Mechanisms may be located in many locations throughout the various Finishers and Sorters available. In this example, it is located near the Stacker Unit.

### 5.3 Theory of Operation (1/2)

Most Stapler mechanisms consist of a Stapler and a Clincher that may be separate or combined into one unit.

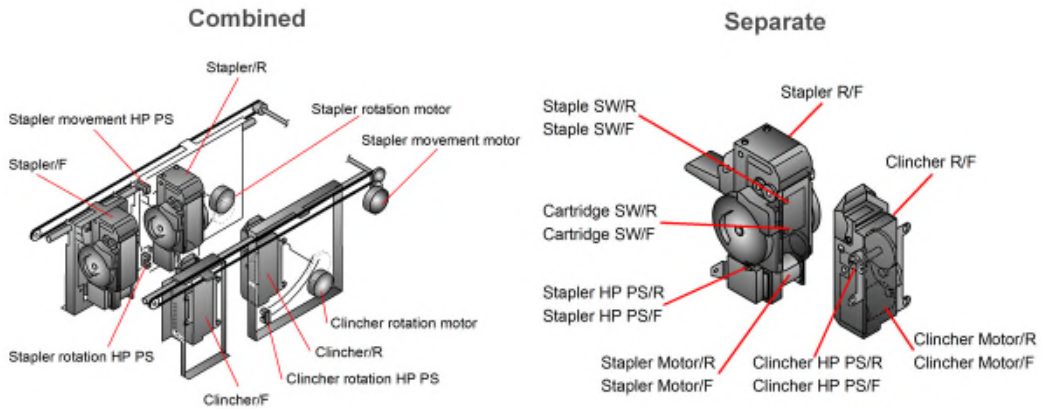

Most Stapler mechanisms consist of a Stapler and a Clincher that may be separate or combined into one unit.

When at least two sheets of paper are fed into the stapler and aligned, a pressure unit or plate compresses the paper against the clincher unit. While this occurs, a cam within the stapler rotates to drive a staple through the paper with the ends of the staple being clinched or bent over, thus completing the process. The pressure unit releases the paper and the stapled sheets exit the Stapler Mechanism.

Depending on the model, a stapler may have a maximum stapling capacity of 30 sheets up to 100 sheets of plain paper, which is dependent upon the type and thickness of the paper. Stapling cartridges may contain as many as 5,000 staples in a roll, or in sheets.



When at least two sheets of paper are fed into the stapler and aligned, a pressure unit or plate compresses the paper against the clincher unit. While this occurs, a cam within the stapler rotates to drive a staple through the paper with the ends of the staple being clinched or bent over, thus completing the process. The pressure unit releases the paper and the stapled sheets exit the Stapler Mechanism.

Depending on the model, a stapler may have a maximum stapling capacity of 30 sheets up to 100 sheets of plain paper, which is dependent upon the type and thickness of the paper. Stapling cartridges may contain as many as 5,000 staples in a roll, or in sheets.

Когда по меньшей мере два листа бумаги загружены в шиватель и выровнены, блок давления или пластина сжимает бумагу с блоком клинкера. В то время как это происходит, кулачок внутри шивателя вращается, чтобы пропустить скрепку через бумагу, при этом концы скрепки сжимаются или сгибаются, тем самым завершая процесс. Блок давления освобождает бумагу, и сшитые листы выходят из механизма шивателя.

В зависимости от модели степлер может иметь максимальную емкость сшивания от 30 до 100 листов обычной бумаги, что зависит от типа и толщины бумаги. Сшивающие картриджи могут содержать до 5000 скрепок в рулоне или в листах.

## 5.4 Preventative Maintenance & Safety

outward  
ASSOCIATE

Inspect the Stapler components for wear and replace as necessary.

Keep fingers away from the stapling unit during a staple cycle as extreme force is used to drive the staples through the set of copies.

Inspect the Stapler components for wear and replace as necessary.

Keep fingers away from the stapling unit during a staple cycle as extreme force is used to drive the staples through the set of copies.

Проверьте детали шивателя на износ и при необходимости замените.

Держите пальцы подальше от блока сшивания во время цикла сшивания, поскольку для перемещения скрепок через комплект копий используется чрезмерная сила.

## 5.5 Removal Procedure

Reference the service manual for the proper removal procedures.

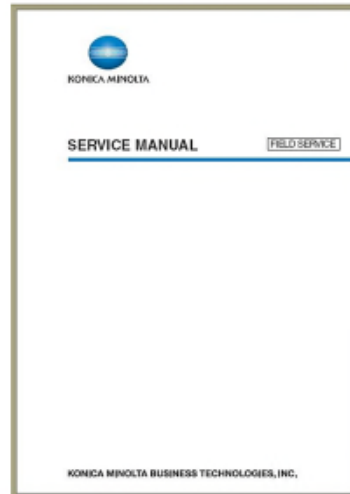

Reference the service manual for the proper removal procedures.

## 5.6 Disassembly/Reassembly

When performing disassembly procedures, observe any drive pins or small parts that could become lost. Also, note the positions of any mechanical adjustments and mark the positions *before* disassembly.

When performing disassembly procedures, observe any drive pins or small parts that could become lost. Also, note the positions of any mechanical adjustments and mark the positions before disassembly.

При выполнении процедур разборки обратите внимание на любые шпильки или мелкие детали, которые могут быть потеряны. Также обратите внимание на положение любых механических регулировок и отметьте их перед разборкой.

## 5.7 Adjustments & Malfunction Codes

Most Stapler Systems require timing adjustments, especially the two-piece systems having separate stapling units and Clinchers. Reference the service manual for the proper adjustment procedures, and alignment or adjustment tools to use.

Malfunction codes will be generated if the stapler jams or fails to move into position to carry out a stapling operation.

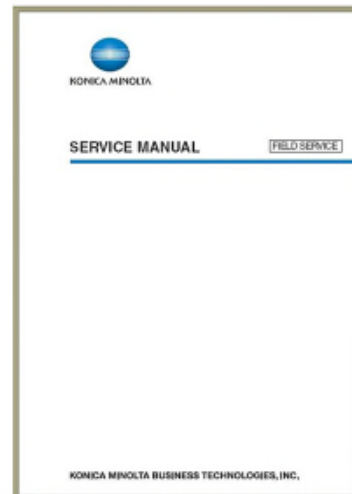

Most Stapler Systems require timing adjustments, especially the two-piece systems having separate stapling units and Clinchers. Reference the service manual for the proper adjustment procedures, and alignment or adjustment tools to use.

Malfunction codes will be generated if the stapler jams or fails to move into position to carry out a stapling operation.

Большинство сшивающих систем требуют регулировки времени, особенно двухсекционные системы, имеющие отдельные шиватели и клинчеры. Обратитесь к руководству по техническому обслуживанию для получения информации о правильных процедурах настройки и используемых инструментах выравнивания или регулировки.

Коды неисправности будут сгенерированы, если шиватель застрянет или не сможет переместиться в положение для выполнения операции сшивания.

## 5.8 Quiz

Question 1 of 2

Staples may be used to create a bound booklet.

- True
- False

### PROPERTIES

On passing, 'Finish' button:

On failing, 'Finish' button:

Allow user to leave quiz:

User may view slides after quiz:

User may attempt quiz:

[Goes to Next Slide](#)

[Goes to Next Slide](#)

[At any time](#)

[At any time](#)

[Unlimited times](#)

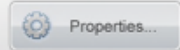

You should now have knowledge of the Stapler Mechanism and how it functions.  
The next topic we will discuss is the Folding Unit and how different folds are produced.

5.9 Review

You should now have knowledge of the Stapler Mechanism and how it functions.  
The next topic we will discuss is the Folding Unit and how different folds are produced.

## Folding Section

The topics of discussion are:

- General Statement
- Location
- Theory of Operation
- Preventative Maintenance & Safety
- Removal Procedure
- Disassembly/Reassembly
- Adjustments
- Malfunction Codes

The following topics within the Folding Section lesson will be covered.

## 6.1 General Statement

Some Finishers and Sorters may be capable of producing booklets by folding sets of copies. They may also be able to produce folds in individual copies such as: half-fold, three-fold, or Z-fold.

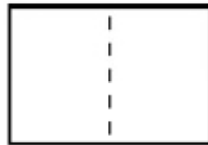

Booklet mode (Half-fold)

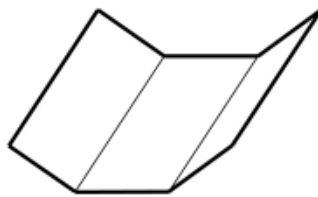

Three-fold



Z-fold

Some Finishers and Sorters may be capable of producing booklets by folding sets of copies. They may also be able to produce folds in individual copies such as: half-fold, three-fold, or Z-fold.

Некоторые финишеры и сортировщики могут создавать буклеты, складывая комплекты копий. Они могут также быть в состоянии произвести сгибы в отдельных копиях, таких как: в два раза, в три раза или в Z-раз.

## 6.2 Location

Most Folding Units are located in the lower half of the finisher and could share some of the same aligning plates as the Stapling Unit.

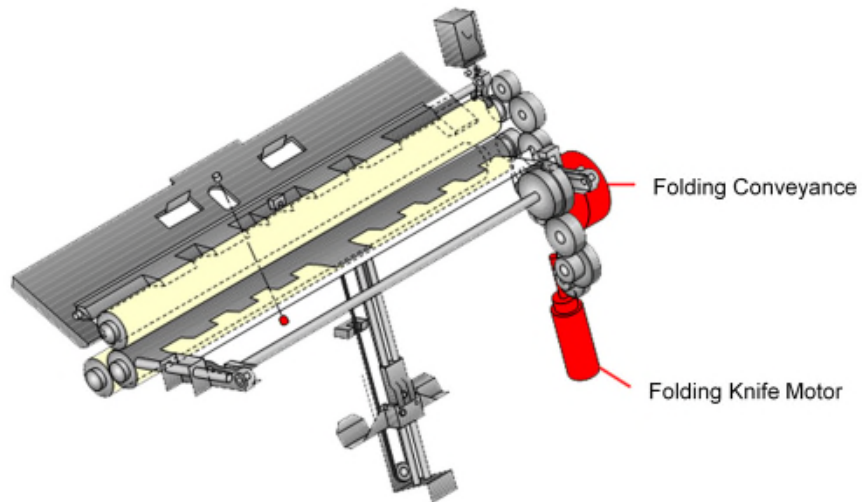

Most Folding Units are located in the lower half of the finisher and could share some of the same aligning plates as the Stapling Unit.

Большинство складных модулей расположены в нижней половине финишера и могут иметь те же выравнивающие пластины, что и сшивающий блок.

## 6.3 Theory of Operation

The Folding Mechanism is quite reliable in that all of the transport and folding rollers remaining turn in the same direction, thus making the operation clutch-free.

The key to this operation is the folding knife, which pushes the paper into the nip of the folding rollers at the appropriate time.

If a sheet of paper is folded in half, the knife presses into the middle of the paper. If a three-fold is performed, the knife presses into one third of the paper.

To complete the second fold, the finisher requires an additional roller called the Three-folding roller.

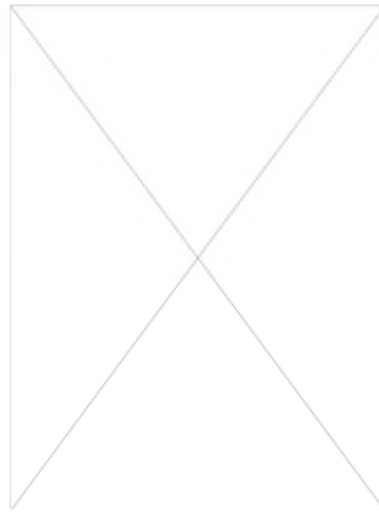

The Folding Mechanism is quite reliable in that all of the transport and folding rollers remaining turn in the same direction, thus making the operation clutch-free.

The key to this operation is the folding knife, which pushes the paper into the nip of the folding rollers at the appropriate time.

If a sheet of paper is folded in half, the knife presses into the middle of the paper. If a three-fold is performed, the knife presses into one third of the paper.

To complete the second fold, the finisher requires an additional roller called the Three-folding roller.

Механизм складывания достаточно надежен в том, что все транспортировочные и складывающие ролики остаются вращающимися в одном направлении, что делает работу без сцепления.

Ключом к этой операции является складной нож, который в нужное время проталкивает бумагу в зазор складывающих роликов.

Если лист бумаги сложен пополам, нож вдавлируется в середину бумаги. Если выполняется три раза, нож вдавливается в одну треть бумаги.

Для завершения второго сгиба финишеру требуется дополнительный ролик, который называется трехстворчатым роликом.

## 6.4 Preventative Maintenance & Safety

Inspect the Folding components for wear and clean or replace as needed.  
Keep fingers away from the nip of the folding rollers.

Inspect the Folding components for wear and clean or replace as needed. Keep fingers away from the nip of the folding rollers.

## 6.5 Removal Procedure

Reference the service manual for the proper removal procedures.

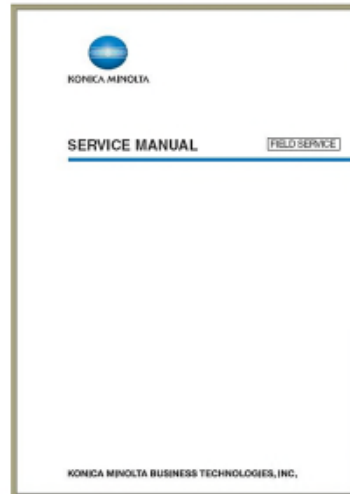

Reference the service manual for the proper removal procedures.

## 6.6 Disassembly/Reassembly

Follow the service procedures as described in the service manuals.

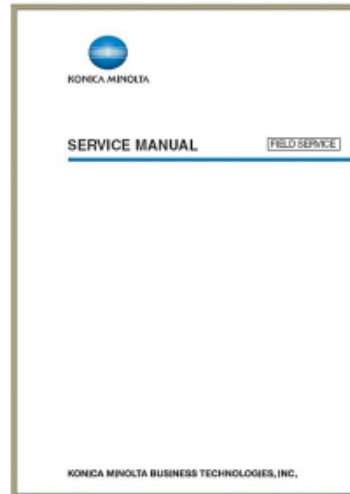

Follow the service procedures as described in the service manuals.

## 6.7 Adjustments

Several adjustments are available for the positions of the particular folds to ensure they are of the proper length according to the specifications.

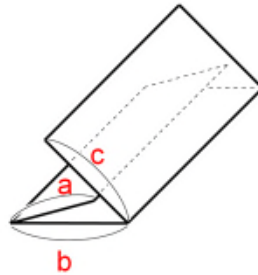

Width/Height	Measurements	Nominal Values		Allowance
		A4S	8 1/2 x 11S	
Width	a	93mm	86.4mm	+ - 2mm
	b	102mm	97mm	+ - 2mm
	c	102mm	97mm	+ - 2mm
Height	h	25mm or less	25mm or less	

Several adjustments are available for the positions of the particular folds to ensure they are of the proper length according to the specifications.

Несколько положений доступны для положений конкретных сгибов, чтобы гарантировать, что они имеют надлежащую длину в соответствии со спецификациями.

## 6.8 Malfunction Codes

There are various Malfunction codes related to the folding unit, reference the Service Manual for the possible cause of the problem.

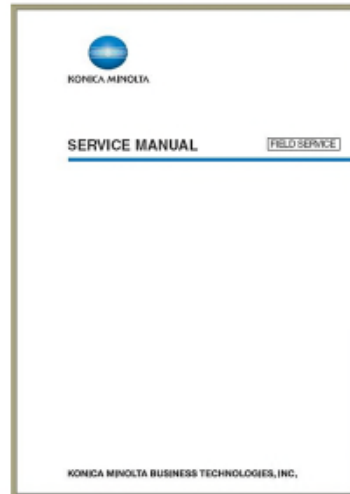

There are various Malfunction codes related to the folding unit, reference the Service Manual for the possible cause of the problem.

## 6.9 Quiz

Question 1 of 2

The Folding Mechanism is very reliable because the rollers remain turning in the same direction.

- True
- False

### PROPERTIES

On passing, 'Finish' button:

On failing, 'Finish' button:

Allow user to leave quiz:

User may view slides after quiz:

User may attempt quiz:

[Goes to Next Slide](#)

[Goes to Next Slide](#)

[At any time](#)

[At any time](#)

[Unlimited times](#)

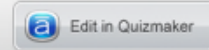
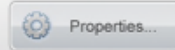

## 6.10 Review

You should now have knowledge of the Folding Unit and how it produces the folds.  
The next topic we will discuss is the Post Inserter and how it functions.

You should now have knowledge of the Folding Unit and how it produces the folds. The next topic we will discuss is the Post Inserter and how it functions.

## Post Inserter

The topics of discussion are:

- General Statement
- Location
- Theory of Operation
- Preventative Maintenance & Disassembly / Assembly
- Adjustments & Codes

The following topics within the Post Inserter lesson will be covered.

## 7.1 General Statement

Some finishers have an optional Post Inserter that manually adds pages to a set of copies.

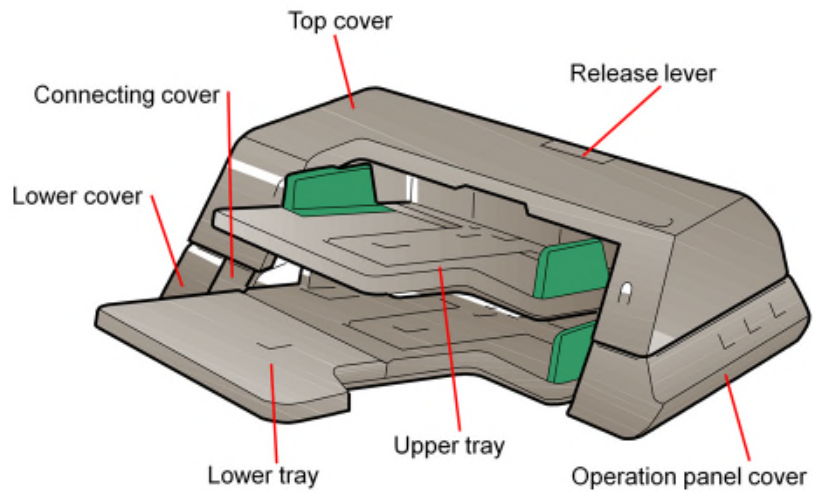

Some finishers have an optional Post Inserter that manually adds pages to a set of copies.

Некоторые финишеры имеют дополнительный Post Inserter, который вручную добавляет страницы в набор копий.

## 7.2 Location

The Post Inserter is installed on top of the finisher.  
Here is a cross-section of the typical components.

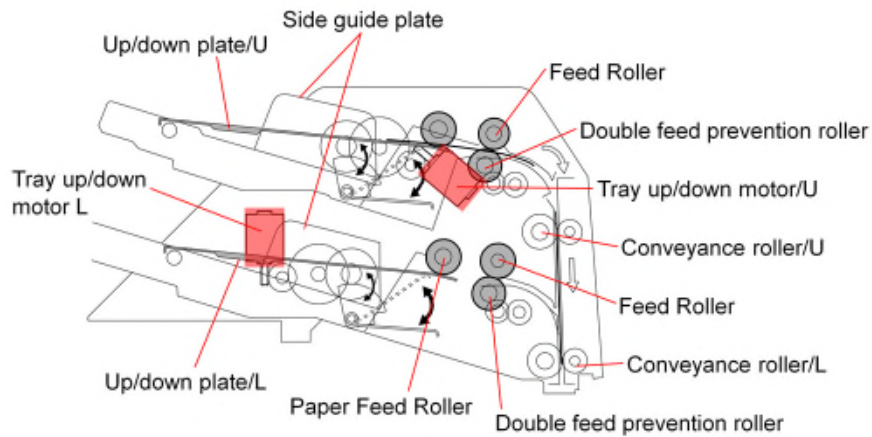

The Post Inserter is installed on top of the finisher. Here is a cross-section of the typical components.

Post Inserter устанавливается поверх финишера. Вот поперечное сечение типичных компонентов.

### 7.3 Theory of Operation

A Post Inserter is basically an additional paper source that feeds stock of various weights, colors, or pre-printed stock into the Finisher and combines it with a copy set to create a booklet.

In this example, the top tray is for automatic feeding, in on-line operation for either copier or printer, without the intervention of a user. The bottom tray is for manual feeding in off-line operation, which enables a user to manually feed printed copies into the Inserter for stapling or folding. The bottom tray does not hold additional stock.



A Post Inserter is basically an additional paper source that feeds stock of various weights, colors, or pre-printed stock into the Finisher and combines it with a copy set to create a booklet.

In this example, the top tray is for automatic feeding, in on-line operation for either copier or printer, without the intervention of a user. The bottom tray is for manual feeding in off-line operation, which enables a user to manually feed printed copies into the Inserter for stapling or folding. The bottom tray does not hold additional stock.

Post Inserter - это, по сути, дополнительный источник бумаги, который подает в финишер запас различных плотностей, цветов или предварительно напечатанный материал и объединяет его с набором копий для создания буклета.

В этом примере верхний лоток предназначен для автоматической подачи в режиме онлайн для копира или принтера без вмешательства пользователя. Нижний лоток предназначен для ручной подачи в автономном режиме, что позволяет пользователю вручную подавать распечатанные копии в Inserter для сшивания или сгибания. Нижний лоток не вмещает дополнительный запас.

Inspect and clean or replace parts as necessary.

Reference the disassembly and reassembly procedures in the respective Post Inserter's Service Manual.

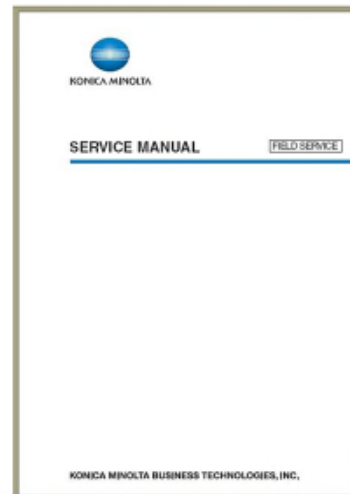

Inspect and clean or replace parts as necessary.

Reference the disassembly and reassembly procedures in the respective Post Inserter's Service Manual.

Осмотрите и очистите или замените детали, если необходимо.

См. Процедуры разборки и повторной сборки в соответствующем Руководстве по обслуживанию после установки.

## 7.5 Adjustments & Codes

Some adjustments are required for Post Inserters. Reference the respective Service Manual for the procedures.

There are also various Malfunction codes related to the unit; again, reference the Service Manual for the source of each code.

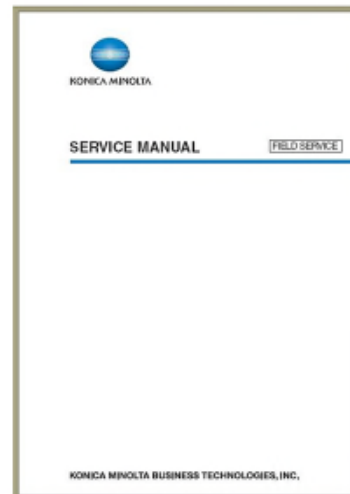

Some adjustments are required for Post Inserters. Reference the respective Service Manual for the procedures.

There are also various Malfunction codes related to the unit; again, reference the Service Manual for the source of each code.

Некоторые настройки требуются для почтовых вставок. Обратитесь к соответствующему руководству по обслуживанию для процедур.

Существуют также различные коды неисправностей, связанные с устройством; Опять же, обратитесь к Руководству по обслуживанию, чтобы узнать источник каждого кода.

## 7.6 Quiz

Question 1 of 2

Post Inserters are optional accessories on some finishers.

- True
- False

### PROPERTIES

On passing, 'Finish' button:

On failing, 'Finish' button:

Allow user to leave quiz:

User may view slides after quiz:

User may attempt quiz:

Goes to Next Slide

Goes to Next Slide

At any time

At any time

Unlimited times

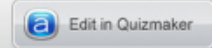
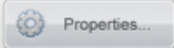

## 7.7 Review

You should now have knowledge of the Post Inserter and its' function.

The next topic we will discuss are Punch Units and their application.

You should now have knowledge of the Post Inserter and its' function.

The next topic we will discuss are Punch Units and their application.

## Punch Unit

The topics of discussion are:

- General Statement
- Location
- Theory of Operation
- Preventative Maintenance
- Safety & Removal Procedure
- Disassembly / Reassembly & Adjustments
- Malfunction Codes & Counters
- Theoretical Troubleshooting

The following topics within the Punch Unit lesson will be covered.

## 8.1 General Statement

Punch Units are available on most finishers or sorters as either standard or optional equipment. Some are capable of punching two, three, or even four holes and may be controlled from the copier, or remotely from a computer when printing.

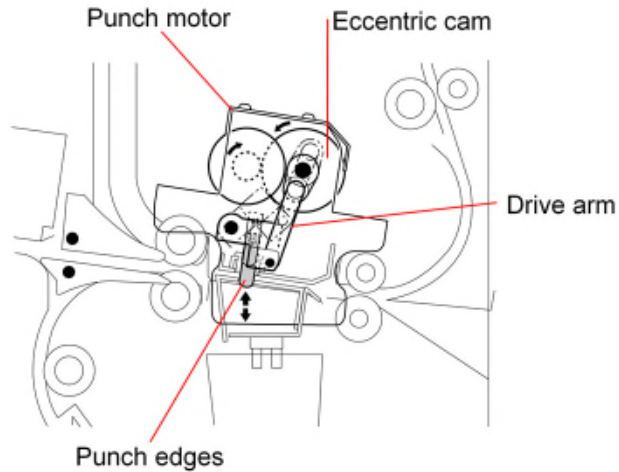

Punch Units are available on most finishers or sorters as either standard or optional equipment. Some are capable of punching two, three, or even four holes and may be controlled from the copier, or remotely from a computer when printing.

Штампы доступны на большинстве финишеров или сортировщиков в качестве стандартного или дополнительного оборудования. Некоторые из них способны пробивать два, три или даже четыре отверстия и могут управляться из копира или удаленно с компьютера при печати.

## 8.2 Location

Punch Units usually occupy the copy paper entrance location of the Finisher or sorter with the Hole Punch Collection Boxes located beneath them.

Here is a cross-section of the typical components.

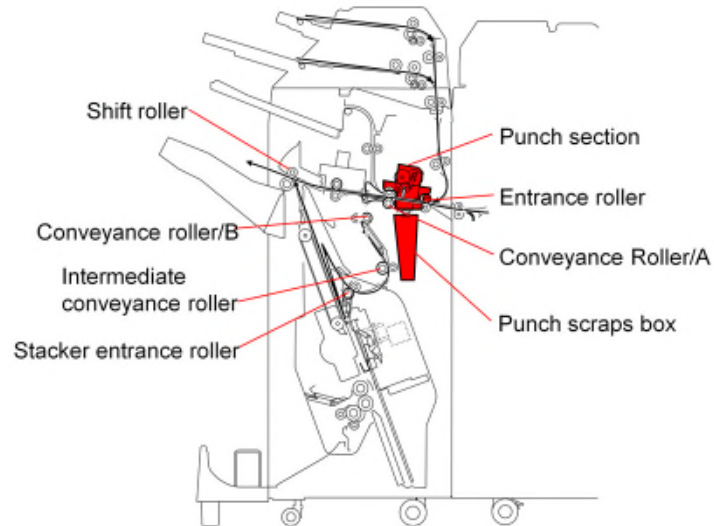

Punch Units usually occupy the copy paper entrance location of the Finisher or sorter with the Hole Punch Collection Boxes located beneath them.

Here is a cross-section of the typical components.

Перфораторы обычно занимают место входа копировальной бумаги финишера или сортировщика с расположенными под ними ящиками для сбора дыроколов. Вот поперечное сечение типичных компонентов.

### 8.3 Theory of Operation

The Hole Punch process is, in most cases, the first process the paper undergoes after exiting the copier or printer.

The Punch Process momentarily stops the paper at the Punch Unit, and punches the paper by rotating an eccentric cam, one for each hole-punch, which in turn drives all of the Punches through the paper sequentially from one side of the paper to the other. Sequential punching is intended to minimize the force needed for the punching operation since one hole is created at a time. This process is completed in a manner as to maintain the maximum rated output speed of the copier or printer. Sometimes this is referred to as 'on-the-fly' Hole Punching.



The Hole Punch process is, in most cases, the first process the paper undergoes after exiting the copier or printer.

The Punch Process momentarily stops the paper at the Punch Unit, and punches the paper by rotating an eccentric cam, one for each hole-punch, which in turn drives all of the Punches through the paper sequentially from one side of the paper to the other. Sequential punching is intended to minimize the force needed for the punching operation since one hole is created at a time. This process is completed in a manner as to maintain the maximum rated output speed of the copier or printer. Sometimes this is referred to as 'on-the-fly' Hole Punching.

Процесс перфорации, в большинстве случаев, является первым процессом, которому бумага подвергается после выхода из копира или принтера.

Процесс перфорирования на мгновение останавливает бумагу в перфораторе и перфорирует бумагу, вращая эксцентриковый кулачок, по одному на каждый перфоратор, который, в свою очередь, продвигает все перфораторы через бумагу последовательно от одной стороны бумаги к другой. , Последовательная перфорация предназначена для минимизации силы, необходимой для операции перфорации, поскольку за один раз создается одно отверстие. Этот процесс выполняется таким образом, чтобы поддерживать максимальную номинальную скорость вывода на копир или принтер. Иногда это называется «перфорацией на лету».

## 8.4 Preventative Maintenance

The Punch Collection Box should be emptied at every Minimum Call, and Preventative Maintenance Procedure. Some boxes are accessible to the user, while others require a technician to empty.

The Punch Collection Box should be emptied at every Minimum Call, and Preventative Maintenance Procedure. Some boxes are accessible to the user, while others require a technician to empty.

Ящик для сбора перфорации следует опустошать при каждом минимальном вызове и процедуре профилактического обслуживания. Некоторые коробки доступны для пользователя, в то время как другие требуют, чтобы технический специалист опустошил.

## 8.5 Safety & Removal Procedure

outward  
ASSOCIATE

Do not allow the Punch Unit to be used to punch anything other than the prescribed type and weight of copy paper as it may jam and damage the unit.  
Reference the service manuals for the removal procedures.

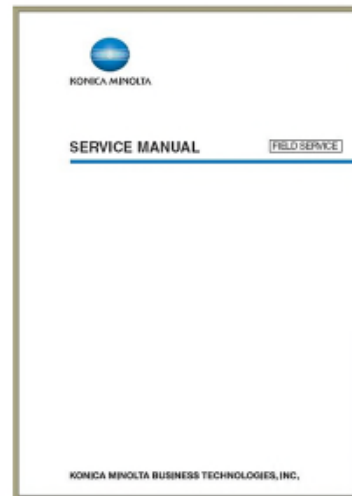

Do not allow the Punch Unit to be used to punch anything other than the prescribed type and weight of copy paper as it may jam and damage the unit.

Reference the service manuals for the removal procedures.

Не допускайте, чтобы перфоратор использовался для перфорирования чего-либо, кроме предписанного типа и веса копировальной бумаги, поскольку это может привести к застреванию и повреждению аппарата.

Обратитесь к руководствам по обслуживанию для процедур удаления.

## 8.6 Disassembly / Reassembly & Adjustments

Reference the service manuals for the disassembly & reassembly procedures, as well as the adjustment procedures.

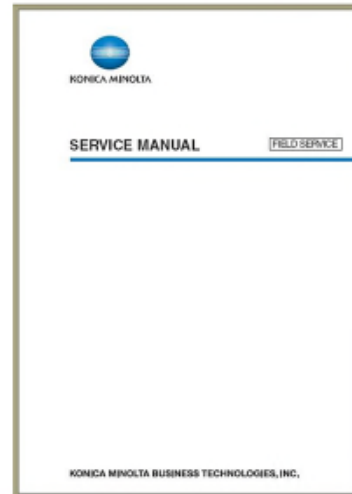

Reference the service manuals for the disassembly & reassembly procedures, as well as the adjustment procedures.

## 8.7 Malfunction Codes & Counters

Some Punch Collection Boxes have a sensor mounted on the chassis of the Punch Unit to detect if the box is full.

Some Punch Units may also generate malfunction codes.

Some Punch Collection Boxes have a sensor mounted on the chassis of the Punch Unit to detect if the box is full.

Some Punch Units may also generate malfunction codes.

Некоторые коробки для сбора перфораторов имеют датчик, установленный на шасси перфоратора, чтобы определить, заполнена ли коробка.

Некоторые перфораторы могут также генерировать коды неисправностей.

## 8.8 Quiz

Question 1 of 2

Punch Units usually occupy the copy paper entrance location of the Finisher or Sorter.

- True
- False

### PROPERTIES

On passing, 'Finish' button:

On failing, 'Finish' button:

Allow user to leave quiz:

User may view slides after quiz:

User may attempt quiz:

[Goes to Next Slide](#)

[Goes to Next Slide](#)

[At any time](#)

[At any time](#)

[Unlimited times](#)

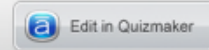
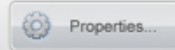

## 8.9 Review

You should now have knowledge of the Hole Punch and how it functions.  
The next topic we will discuss is the Trimmer and its' function.

You should now have knowledge of the Hole Punch and how it functions.  
The next topic we will discuss is the Trimmer and its' function.

## Trimmer

The topics of discussion are:

- General Statement
- Location
- Theory of Operation
- Preventative Maintenance
- Safety & Removal Procedure
- Disassembly / Reassembly & Adjustments
- Malfunction Codes & Counters
- Theoretical Troubleshooting

The following topics within the Trimmer lesson will be covered.

## 9.1 General Statement

A Trimmer is an optional device that is capable of trimming the uneven edges from a booklet to produce clean, neatly aligned edges.

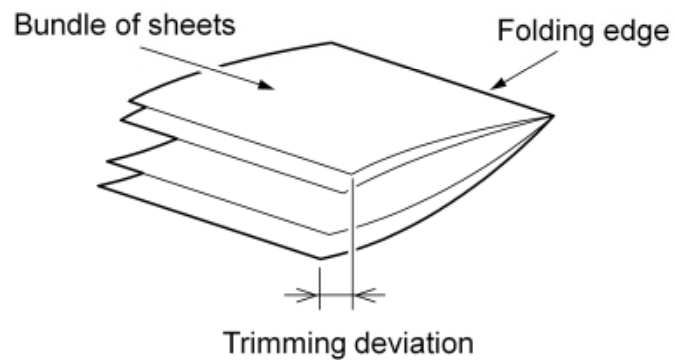

A Trimmer is an optional device that is capable of trimming the uneven edges from a booklet to produce clean, neatly aligned edges.

Триммер - это дополнительное устройство, которое способно обрезать неровные края буклета для получения чистых, аккуратно выровненных краев.

## 9.2 Location

The trimmers are usually mounted to the exit end of a finisher capable of supporting a trimmer.

Trimmers can also be included within other finishers, like a Saddle Stitcher.

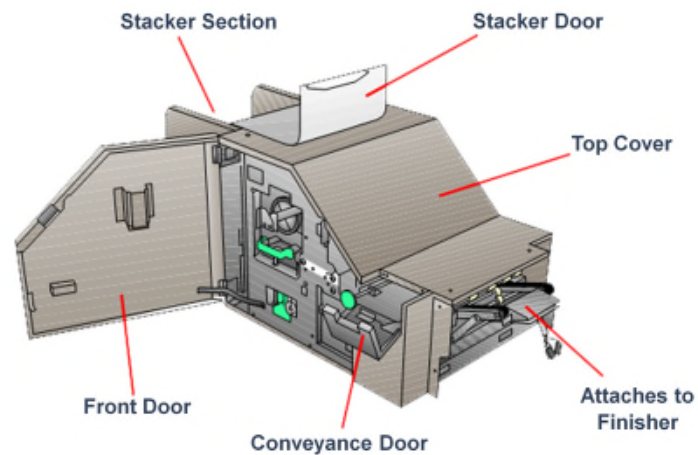

The trimmers are usually mounted to the exit end of a finisher capable of supporting a trimmer.

Trimmers can also be included within other finishers, like a Saddle Stitcher.

Триммеры обычно устанавливаются на выходном конце финишера, способного поддерживать триммер.

Триммеры также могут быть включены в другие финишеры, такие как брошюровщик.

### 9.3 Theory of Operation

A stapled booklet is conveyed from the finisher to the trimming blade, where the blade is lowered to cut through the ends of the paper to straighten out the edges.

Once the edges are trimmed, the booklets are transported out of the trimmer to the Exit Tray.



A stapled booklet is conveyed from the finisher to the trimming blade, where the blade is lowered to cut through the ends of the paper to straighten out the edges.

Once the edges are trimmed, the booklets are transported out of the trimmer to the Exit Tray.

Сшитый буклет передается от финишера к обрезному лезвию, где лезвие опускается, чтобы прорезать концы бумаги, чтобы выровнять края.

Как только края обрезаны, буклеты транспортируются из триммера в выходной лоток.

## 9.4 Preventative Maintenance

The Scraps Collection Box needs to be emptied at every Minimum Call, and Preventative Maintenance Procedure. Some boxes are accessible to the user, while others require a technician to empty.

The Scraps Collection Box needs to be emptied at every Minimum Call, and Preventative Maintenance Procedure. Some boxes are accessible to the user, while others require a technician to empty.

Ящик для сбора отходов необходимо очищать при каждом минимальном вызове и процедуре профилактического обслуживания. Некоторые коробки доступны для пользователя, в то время как другие требуют, чтобы технический специалист опустошил.

## 9.5 Safety & Removal Procedure

outward  
ASSOCIATE

Do not operate the blade with the covers removed. Your fingers can be easily sliced. Use extreme care near the blade to avoid injury.

Reference the service manuals for the removal procedures.

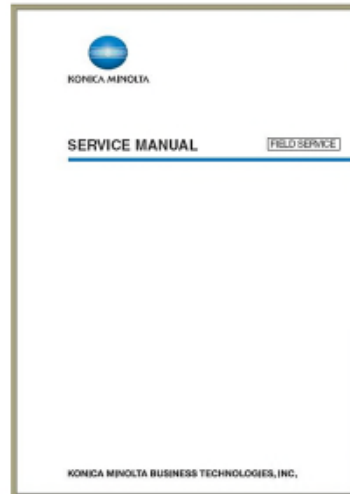

Do not operate the blade with the covers removed. Your fingers can be easily sliced. Use extreme care near the blade to avoid injury.

Reference the service manuals for the removal procedures.

Не используйте лезвие со снятыми крышками. Ваши пальцы могут быть легко нарезаны. Будьте предельно осторожны возле лезвия, чтобы избежать травм.

Обратитесь к руководствам по обслуживанию для процедур удаления.

## 9.6 Disassembly / Reassembly & Adjustments

outward  
ASSOCIATE

Reference the service manuals for the disassembly & reassembly procedures, as well as the adjustment procedures.

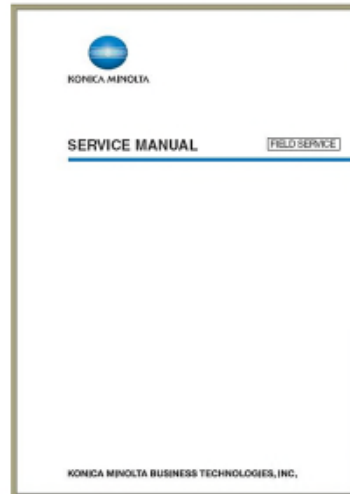

Reference the service manuals for the disassembly & reassembly procedures, as well as the adjustment procedures.

Обратитесь к руководствам по обслуживанию для процедур разборки и сборки, а также процедур регулировки.

## 9.7 Malfunction Codes & Counters

Some Scrap Collection Boxes have a sensor mounted on the chassis of the Trimmer to detect a full box condition. Some Trimmers may also generate malfunction codes.

Some Scrap Collection Boxes have a sensor mounted on the chassis of the Trimmer to detect a full box condition. Some Trimmers may also generate malfunction codes.

В некоторых коробках для сбора отходов имеется датчик, установленный на шасси триммера для определения состояния полной коробки. Некоторые триммеры также могут генерировать коды неисправностей.

## 9.8 Quiz

Question 1 of 2

The Scraps Collection Box needs to be emptied and can be accessible to the user.

- True
- False

### PROPERTIES

On passing, 'Finish' button:

On failing, 'Finish' button:

Allow user to leave quiz:

User may view slides after quiz:

User may attempt quiz:

Goes to Next Slide

Goes to Next Slide

At any time

At any time

Unlimited times

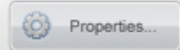

## 9.9 Review

You should now have knowledge of the Trimmer and its' capabilities.  
The next topic we will discuss is the Perfect Binder and how it functions.

You should now have knowledge of the Trimmer and its' capabilities.  
The next topic we will discuss is the Perfect Binder and how it functions.

## Perfect Binder

The topics of discussion are:

- General Statement
- Location
- Theory of Operation
- Preventative Maintenance
- Safety & Removal Procedure
- Disassembly / Reassembly & Adjustments
- Malfunction Codes & Counters
- Theoretical Troubleshooting

The following topics within the Perfect Binder lesson will be covered.

## 10.1 General Statement

A Perfect Binder is an optional device that is capable of binding pages of a large document together with glue to produce clean, professional looking booklets.

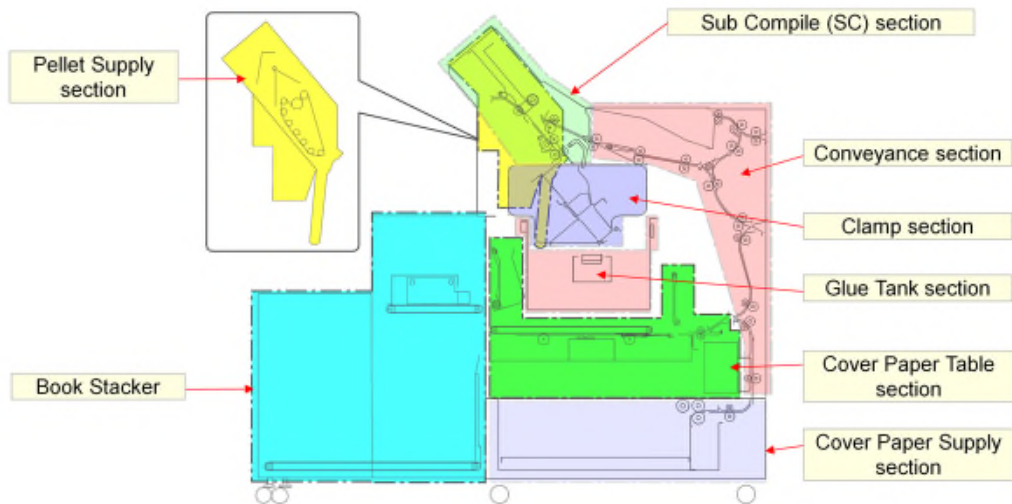

A Perfect Binder is an optional device that is capable of binding pages of a large document together with glue to produce clean, professional looking booklets.

Perfect Binder - это дополнительное устройство, которое способно склеивать страницы большого документа вместе с клеем для получения чистых, профессионально выглядящих буклетов.

## 10.2 Location

Perfect Binders are self contained optional finishers that attach onto MFPs. They are always set up as a terminating finisher. Here are some examples of combinations with a Perfect Binder. The Perfect Binders are highlighted in yellow.

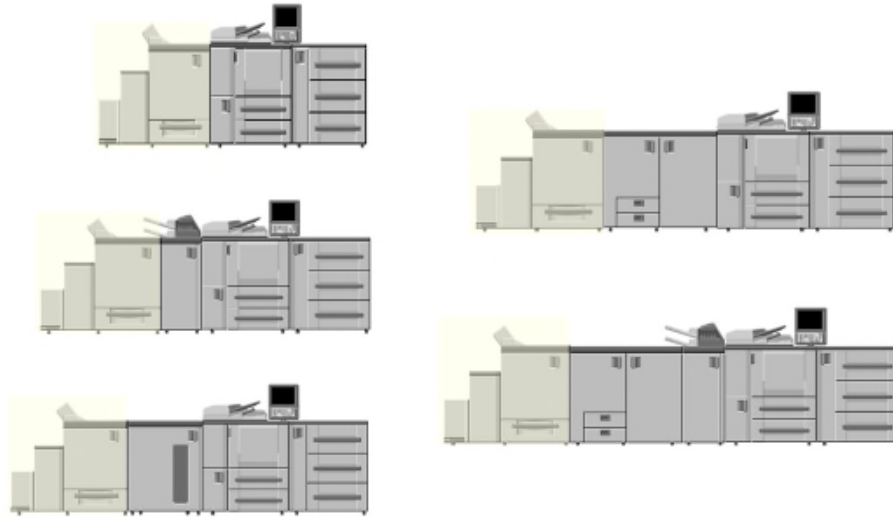

Perfect Binders are self contained optional finishers that attach onto MFPs. They are always set up as a terminating finisher.

Perfect Binder - это автономные дополнительные финишеры, которые прикрепляются к МФУ. Они всегда устанавливаются как завершающий финишер. Вот несколько примеров комбинаций с Perfect Binder. Perfect Binder выделены желтым цветом.

### 10.3 Theory of Operation

Paper is conveyed from either the main body or from another finisher to the Perfect Binder, where it is stacked. The Perfect Binder heats glue which it applies to one side of the stacked paper. It then attaches an outer cover to the other side of the glue and folds the cover over the paper stack. The booklets are then transported out of the Perfect Binder to the Exit Tray.

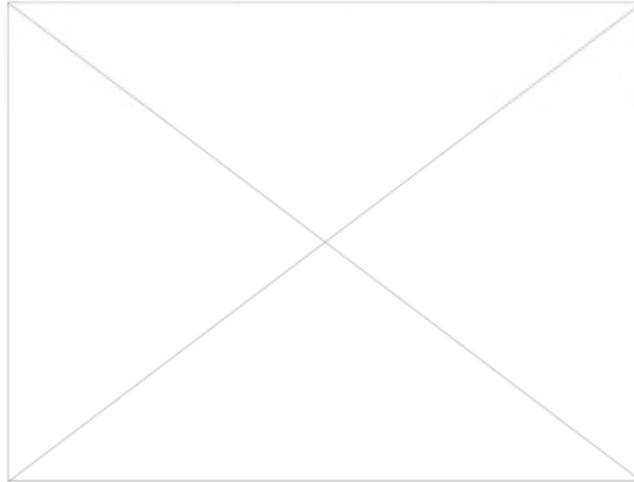

Paper is conveyed from either the main body or from another finisher to the Perfect Binder, where it is stacked. The Perfect Binder heats glue which it applies to one side of the stacked paper. It then attaches an outer cover to the other side of the glue and folds the cover over the paper stack. The booklets are then transported out of the Perfect Binder to the Exit Tray.

Бумага подается из основного корпуса или из другого финишера в устройство Perfect Binder, где она укладывается в стопку. Perfect Binder нагревает клей, который наносится на одну сторону стопки бумаги. Затем он прикрепляет внешнюю крышку к другой стороне клея и складывает крышку поверх стопки бумаги. Затем буклеты транспортируются из Perfect Binder в выходной лоток.

## 10.4 Preventative Maintenance

Refer to the Perfect Binder Service Manual for any Preventative Maintenance Procedures.

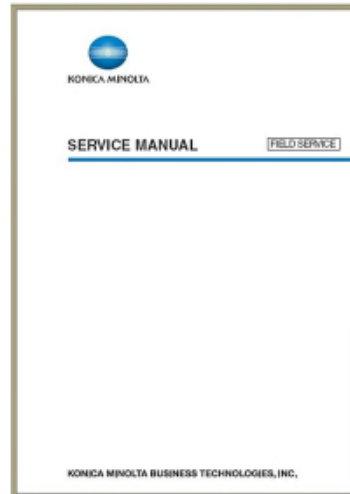

Refer to the Perfect Binder Service Manual for any Preventative Maintenance Procedures.

## 10.5 Safety & Removal Procedure

Be careful around the glue tank. The glue is extremely hot and can burn the skin.  
Reference the service manuals for the Removal procedures.

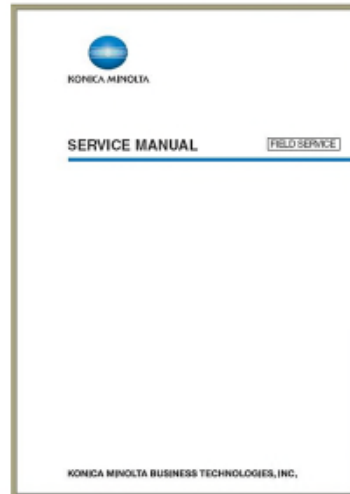

Be careful around the glue tank. The glue is extremely hot and can burn the skin.  
Reference the service manuals for the Removal procedures.

## 10.6 Disassembly / Reassembly & Adjustments

Reference the service manuals for the disassembly & reassembly procedures, as well as the adjustment procedures.

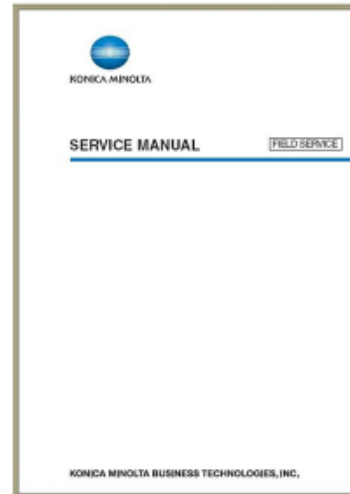

Reference the service manuals for the disassembly & reassembly procedures, as well as the adjustment procedures.

## 10.7 Malfunction Codes & Counters

Reference the service manuals for any related malfunction codes and service counters.

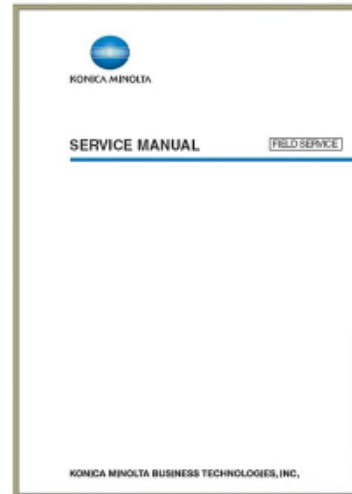

Reference the service manuals for any related malfunction codes and service counters.

## 10.8 Quiz

Question 1 of 2

Perfect Binders use a stitch to hold large documents together.

- True
- False

### PROPERTIES

On passing, 'Finish' button:

On failing, 'Finish' button:

Allow user to leave quiz:

User may view slides after quiz:

User may attempt quiz:

[Goes to Next Slide](#)

[Goes to Next Slide](#)

[At any time](#)

[At any time](#)

[Unlimited times](#)

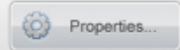

## 10.9 Review

You should now have knowledge of the Perfect Binder, the general theory and its basic features and functions.

You should now have knowledge of the Perfect Binder, the general theory and its basic features and functions.

Congratulations, you have completed the OUTWARD Associate Finishing Systems course. You should now be able to do the following:

- Identify the different types of Finishing Systems and the components within them.
- Explain the theory of operation of these systems.
- Explain the maintenance procedures associated with these systems.
- Reference the various types of service support documentation available to the technician.
- Comply with any safety concerns.

Congratulations, you have completed the OUTWARD Associate Finishing Systems course. You should now be able to do the following:

- Identify the different types of Finishing Systems and the components within them.
- Explain the theory of operation of these systems.
- Explain the maintenance procedures associated with these systems.
- Reference the various types of service support documentation available to the technician.
- Comply with any safety concerns.